

Product Specifications

50EAN205NA6

RIGHT ANGLE CORDED NUTRUNNER
41 - 205 Nm (30.2 – 151.2 ft-lbs)

RIGHT ANGLE - 50 SERIES

The NeoTek™ fastening system is the next generation of smart tool solutions. The lightweight, ergonomic design along with fully programmable features such as the high-output LED light rings, audible alerts, and handle vibration all create a better user experience that leads to decreased operator fatigue and increased productivity.

FEATURES

- 1 million cycles maintenance-free*
- Repeatability & accuracy with 2.0 Cm/Cmk at +/- 7%
- 21% lighter (tool/cable system) than existing tool family
- Digital communication for reliable performance
- Internal temperature monitoring
- Configurable LED light rings
- Data logging with on-board tool memory
- Preventive maintenance alerts
- Compatible with:
 - mPro400GCD-P Controller
 - 961560-xxx Tool Cable
 - 961561-xxx Tool Extension Cable

SPECIFICATIONS

TORQUE RANGE (Nm)

Min / Max: 41 / 205

TORQUE RANGE (ft-lb)

Min / Max: 30.2 / 151.2

SPEED

r/min: 250

WEIGHT & DIMENSIONS

Weight 3.93 kg / 8.66 lb
 Length 562 mm / 22.13 in
 Side to Center 29.5 mm / 1.16 in
 Height 62.0 mm / 2.44 in
 Output Drive 3/4" Sq. Drive
 Country of Origin: Assembled in USA

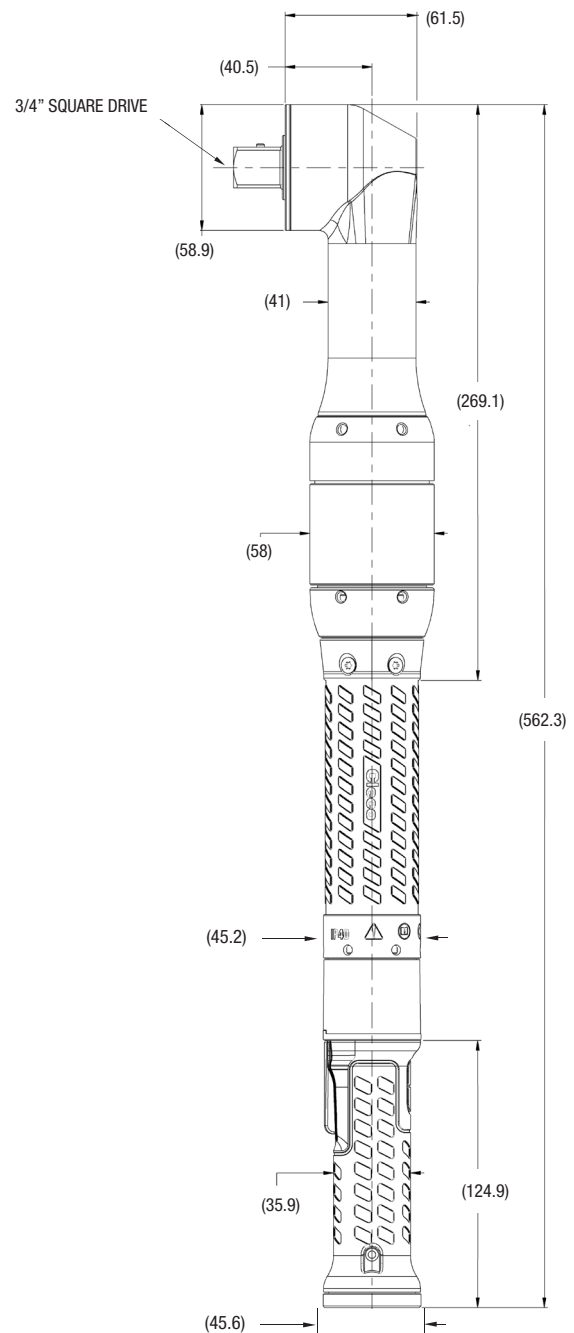

(Units are in metric)

Apex Tool Group, LLC

Phone: +1 (800) 845-5629

Phone: +1 (919) 387-0099

Phone: +49 (0)7363 81-0

www.ClecoTools.com / www.ClecoTools.de

*based on recommended tool model torque range and clockwise rotation